

DIMENSIONS

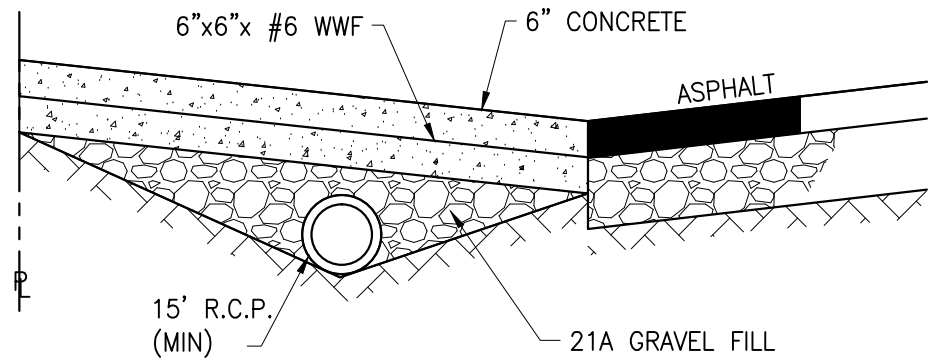

CONCRETE APRON

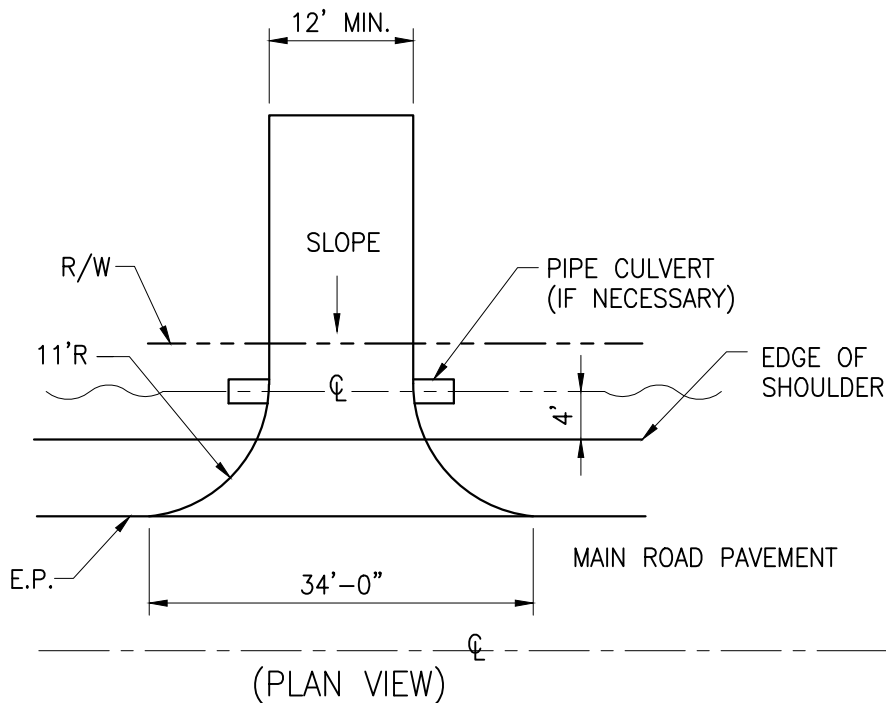

(PLAN VIEW)

NOTES:

- ALL CONSTRUCTION AND MATERIALS SHALL CONFORM, WHERE APPLICABLE, TO THE CURRENT VIENNA CONSTRUCTION SPECIFICATIONS.
- ONLY CONCRETE PIPE MAY BE USED. INDICATE TYPE AND SIZE ON PLANS.
- ALL DRIVEWAY GRADES SHALL START BACK OF THE SHOULDER LINE. IN CUT SECTIONS, SIDES OF DRIVEWAY SHALL BE GRADED TO A MAXIMUM 3:1 SLOPE.
- LENGTHS OF CULVERTS IF NOT SHOWN ON PLANS SHALL BE A MINIMUM OF 20'.
- *DITCH LINE MAY BE MOVED BACK TO PROVIDE REQUIRED COVER. THE TRANSITION OF THE DITCH LINE SHALL BE SMOOTH WITH MINIMUM LENGTH OF 10'.

DRIVEWAY CLEARANCES:

- GRADING PLANS MUST PROVIDE FOR ADEQUATE VEHICULAR CLEARANCE FOR DRIVEWAY APPROACH, DEPARTURE AND BREAKOVER TRANSITIONS.
- DRIVEWAY PROFILES ARE REQUIRED WHERE SLEEP GRADES PREVAIL.

